

# Billing



# Boats®

## EMILE ROBIN 430

PHOTO MANUAL



**DK EMILEROBIN**

MRB 20 "Emile Robin" er afleveret fra Nordsøværftet i Ringkøbing i 1989. Redningsbåden er navngivet efter den parisiske storkøbmand Emile Robin, filantrop, cognacfabrikant og vicepræsident i den franske velgørende sammenslutning La Société Centrale de Sauvetage des Naufragés (Selskabet for skibbrudnes redning). Han står som den mest betydningsfulde velgører i Det danske Redningsvæsens 150-årige historie.

MRB 20 "Emile Robin" er fast stationeret ved Redningsstationen i Hvide Sande.

**GB EMILEROBIN**

MRB 20 "Emile Robin" was delivered from the North Sea Shipyard in Ringkøbing, Denmark, in 1989. The lifeboat was named after the Parisian merchant Emile Robin, a philanthropist, cognac manufacturer and vice-president of the French charity La Société Centrale de Sauvetage des Naufragés (Society for the Salvation of Shipwrecks). Emile Robin is one of the most important benefactors in the 150 year history of the Danish Lifeboat Service. MRB 20 "Emile Robin" is permanently stationed at the lifeboat station in Hvide Sande, on the western coast of Denmark.

**D EMILEROBIN**

Die MRB 20 Emile Robin wurde im Jahre 1989 in der Werft North Sea Shipyard in Ringkøbing/Dänemark gebaut. Der Pariser Kaufmann Emile Robin war Namensgeber dieses Rettungsbootes. Der Philanthropist Emile Robin, ein Cognac-Fabrikant und der Vizepräsident der französischen Gesellschaft für die Rettung von Schiffbrüchigen (La Société Centrale de Sauvetage des Naufragés) war einer der bekanntesten Wohltäter in der 150jährigen Geschichte der dänischen Rettungsschiffahrt. Die Emile Robin hat ihren ständigen Liegeplatz bei der Rettungsstation in Hvide Sande, an der Westküste Dänemarks.

**F EMILEROBIN**

Le MRB 20 "Emile Robin" a été livré du chantier naval de la Mer du Nord à Ringkøbing, Danemark, en 1989. Le bateau de sauvetage a été baptisé du nom du marchand parisien Emile Robin, un philanthrope, fabricant de cognac et de vice-président de la Société Française des Naufragés (Société Centrale de Sauvetage et de charité pour le salut des naufragés). Emile Robin est l'un des bienfaiteurs les plus importants dans l'histoire des 150 ans du service danois des bateaux de sauvetage. MRB 20 „Emile Robin“ est de manière permanente posté à la station de bateaux de sauvetage dans Hvide Sande, sur la côte occidentale du Danemark.

**NL EMILEROBIN**

De MRB 20 "Emile Robin" werd in 1989 afgeleverd door de North Sea Shipyard in Ringkøbing, Denemarken. Deze reddingsboot werd genoemd naar de Parijzenaar Emile Robin, filantroop, cognacmaker en vice-president van de Franse Société Centrale de Seauvetage des Naufragés (Stichting voor de redding van schipbreukelingen). Emile Robin was een van de belangrijkste weldoeners in de 150-jarige geschiedenis van de Deense Reddingsmaatschappij. De MRB 20 „Emile Robin“ is permanent gestationeerd bij het reddingsstation in Hvide Sande aan de westkust van Denemarken.

**E EMILEROBIN**

MRB 20 "Emile Robin" fue entregado por los Astilleros del Mar del Norte en Ringkøbing, Dinamarca en 1989. Este barco de salvamento debe su nombre a un famoso comerciante Parisino llamado Emile Robin que a la vez era filántropo, fabricante de cognac y vicepresidente de la Sociedad de Salvamento de Naufragios (Society for the Salvation of Shipwrecks). Emile Robin ha sido uno de los benefactores más importantes del Servicio de Rescate Marítimo Danés durante sus 150 años de existencia. El MRB 20 Emile Robin tiene su base permanente en Hvide Sande en la costa oeste de Dinamarca.

**I EMILEROBIN**

La MRB 20 "Emile Robin" è stata consegnata dai cantieri navali del Mare del Nord nel 1989. La scialuppa di salvataggio ha preso il nome dal gran commerciante francese Emile Robin, filantropo, produttore di cognac e vicepresidente dell'associazione francese di beneficenza La Société Centrale de Sauvetage des Naufragés (Società francese per il salvataggio dei naufragati). Robin è il più importante benefattore nei 150 anni di storia del Servizio di Salvataggio danese.

La MRB 20 "Emile Robin" staziona permanentemente presso la Centrale di Salvataggio di Hvide Sande.







**P EMILEROBIN**

Em 1989, o MRB 20 "Emile Robin" foi entregue pelo Nordsøværftet (Estaleiro do Mar do Norte). O barco de salvamento foi denominado segundo o grande comerciante parisiense Emile Robin, filantropo, fabricante de conhaque e vice-presidente da sociedade beneficente francesa La Société Centrale de Sauvetage des Naufragés (Sociedade para o Salvamento dos Náufragos). Ele é o maior benfeitor da história sesquicentenária da Det danske Redningsvæsen (Serviço de Salvamento da Dinamarca).

O MRB 20 "Emile Robin" está permanente de prontidão no Posto de Salvamento de Hvide Sande.

**PL EMILEROBIN**

MRB 20 „Emile Robin“ została dostarczona ze stoczni North Sea Shipyard w Ringkøbing w Danii w 1989 roku. Łódź ratunkowa została nazwana na cześć paryskiego kupca Emile'a Robin`a, filantropa, producenta koniaku i wiceprezesa francuskiej organizacji charytatywnej La Société Centrale de Sauvetage des Naufragés (Towarzystwo Ratowania Wraków Statków). Emile Robin jest jednym z najważniejszych dobroczyńców w 150-letniej historii Duńskiej Służby Ratunkowej. MRB 20 „Emile Robin” na stałe stacjonuje na stacji łodzi ratunkowych w Hvide Sande, na zachodnim wybrzeżu Danii.

	Part number		Drill a hole
	Paint number		Use putty (fill and sand)
	Give shape (for example use sand paper)		Part made with layers
	Cut out		

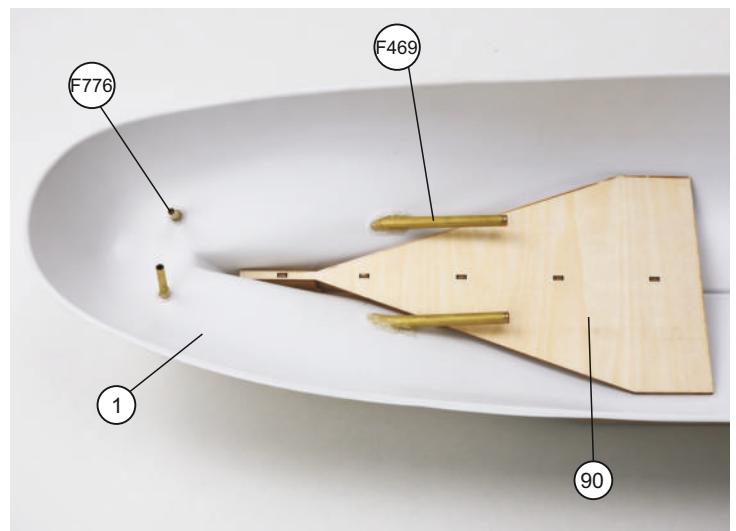
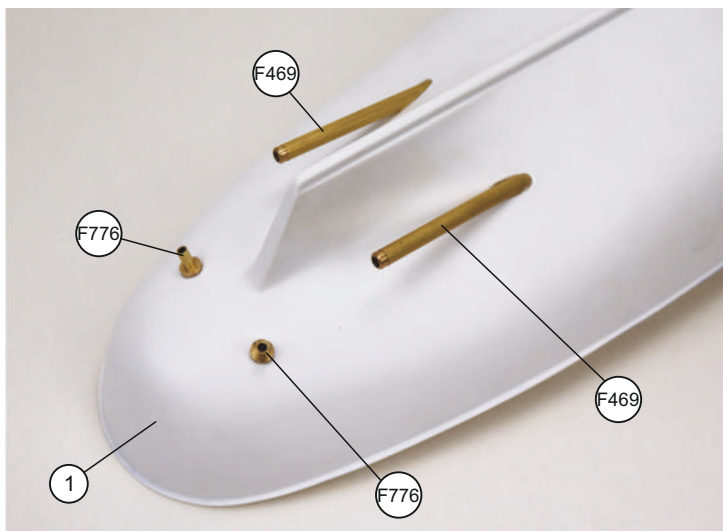
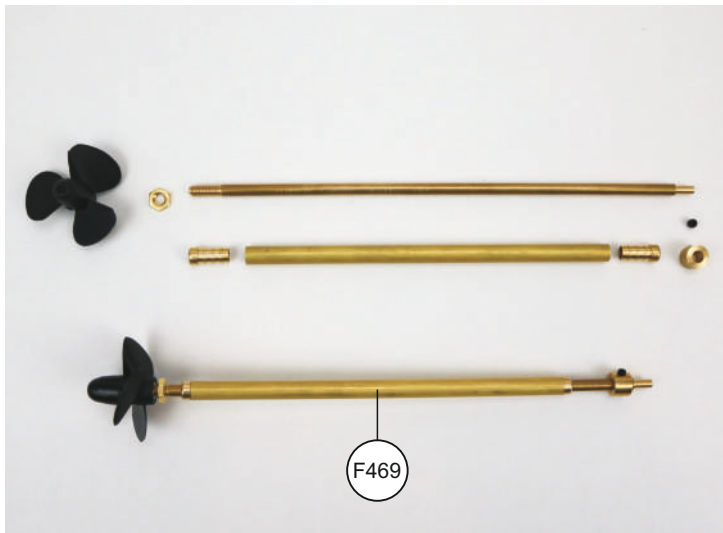
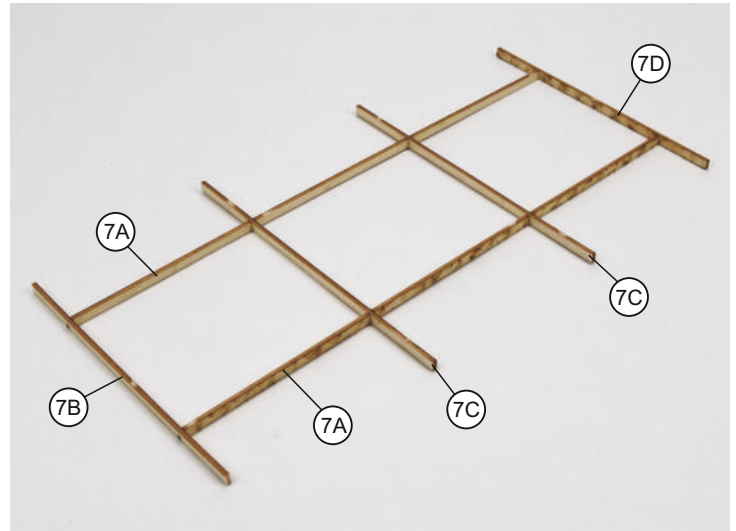
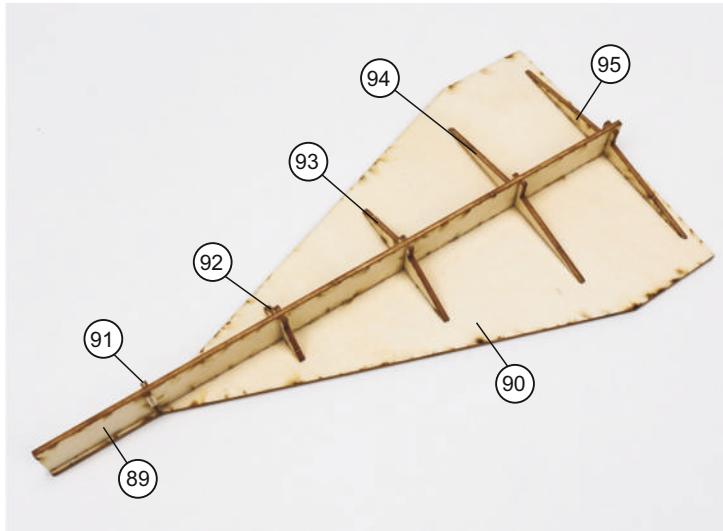
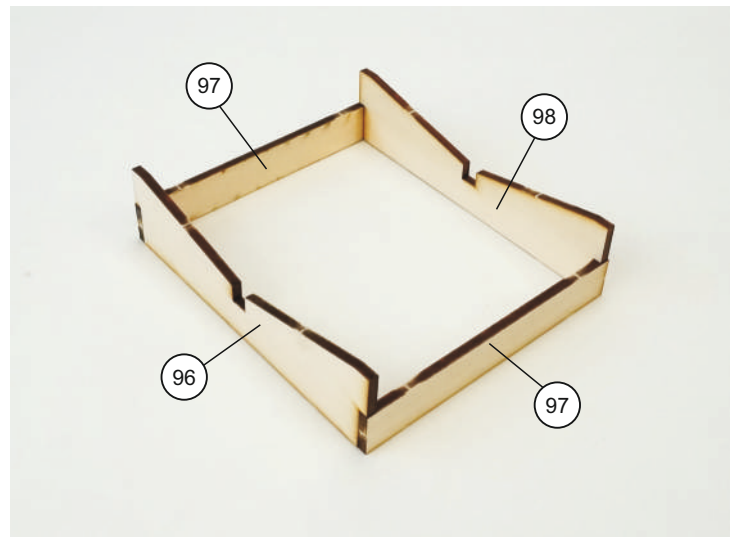
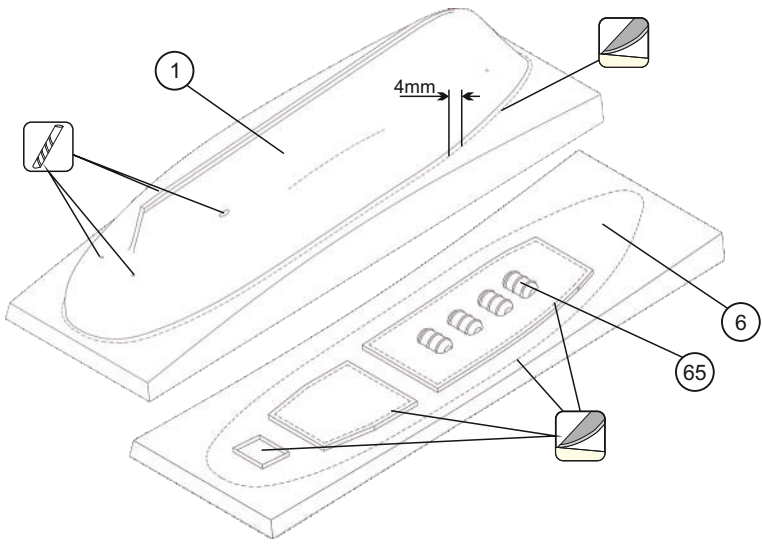

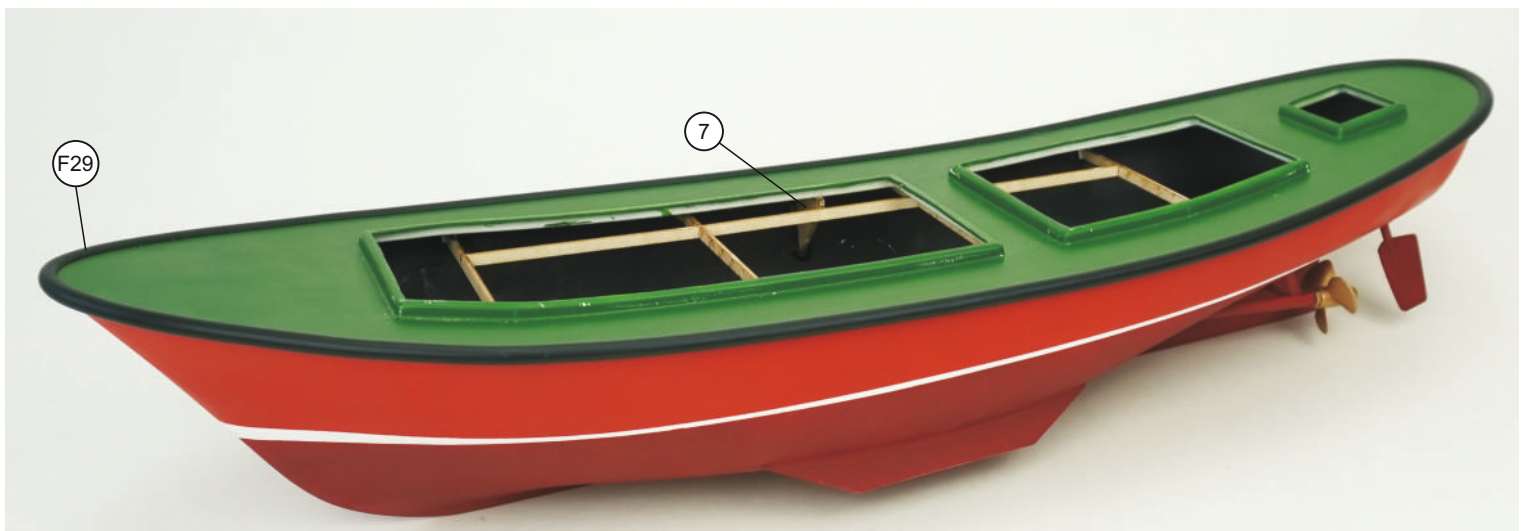
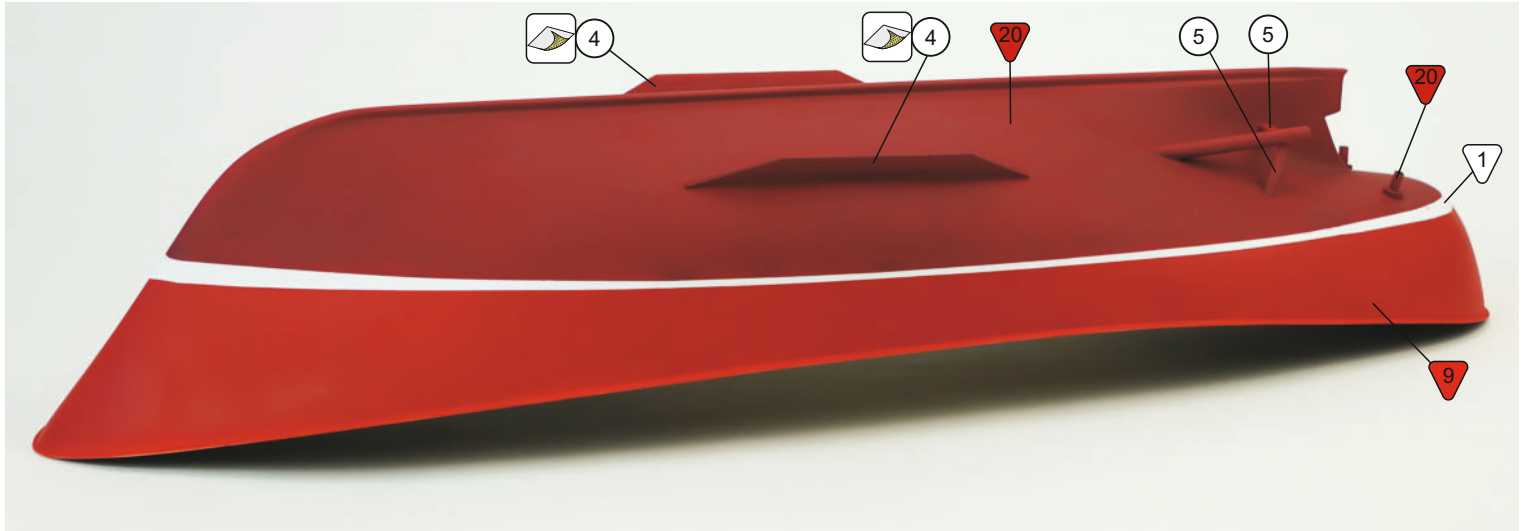
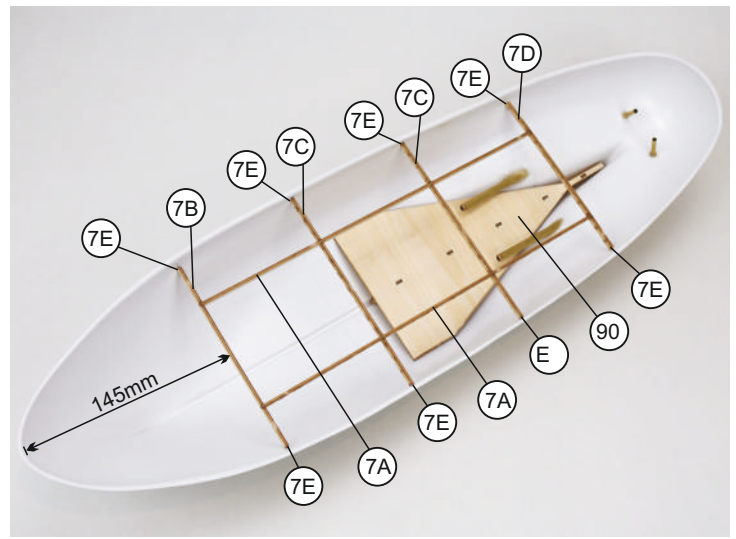
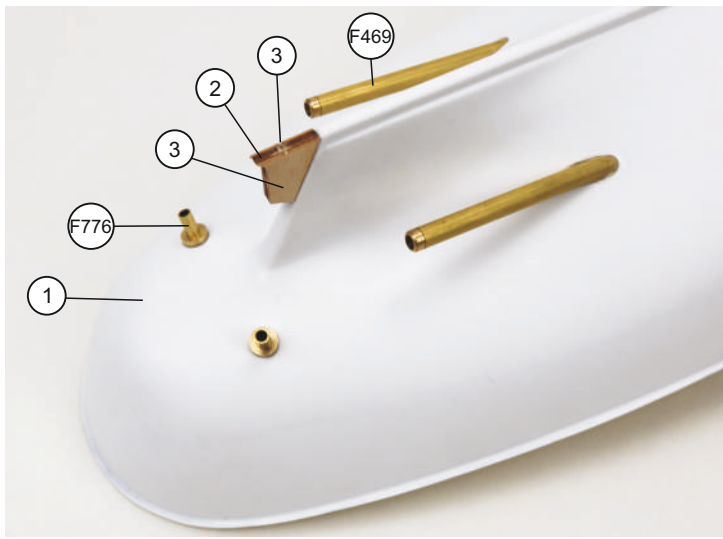

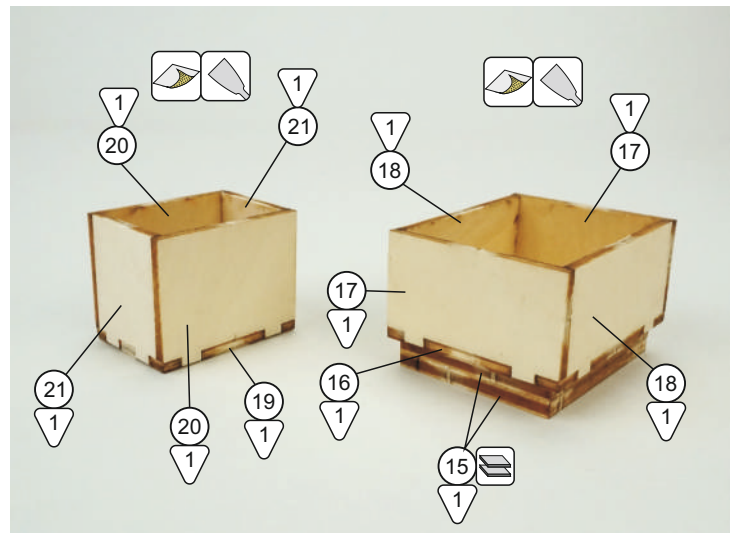
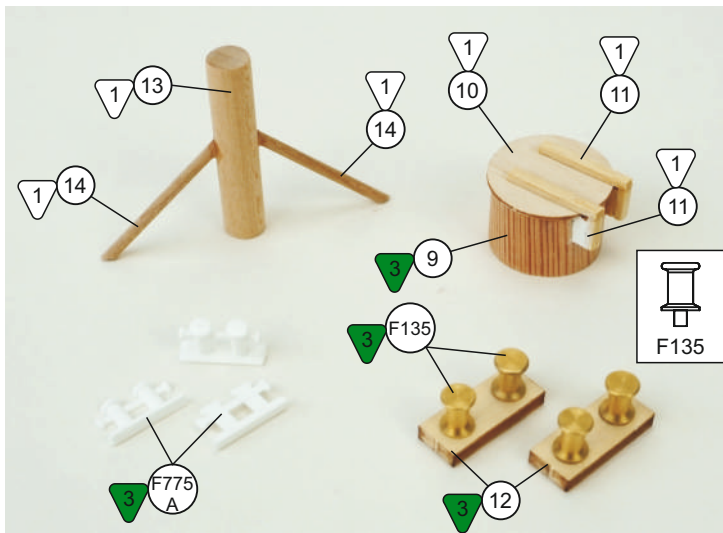
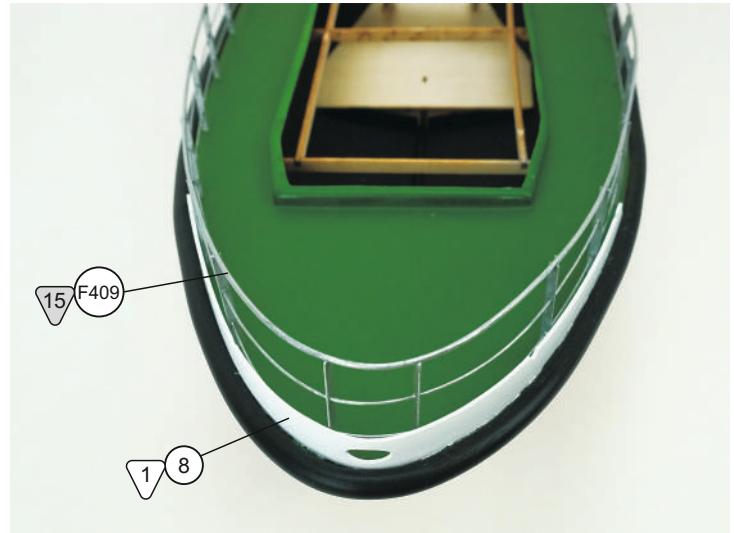
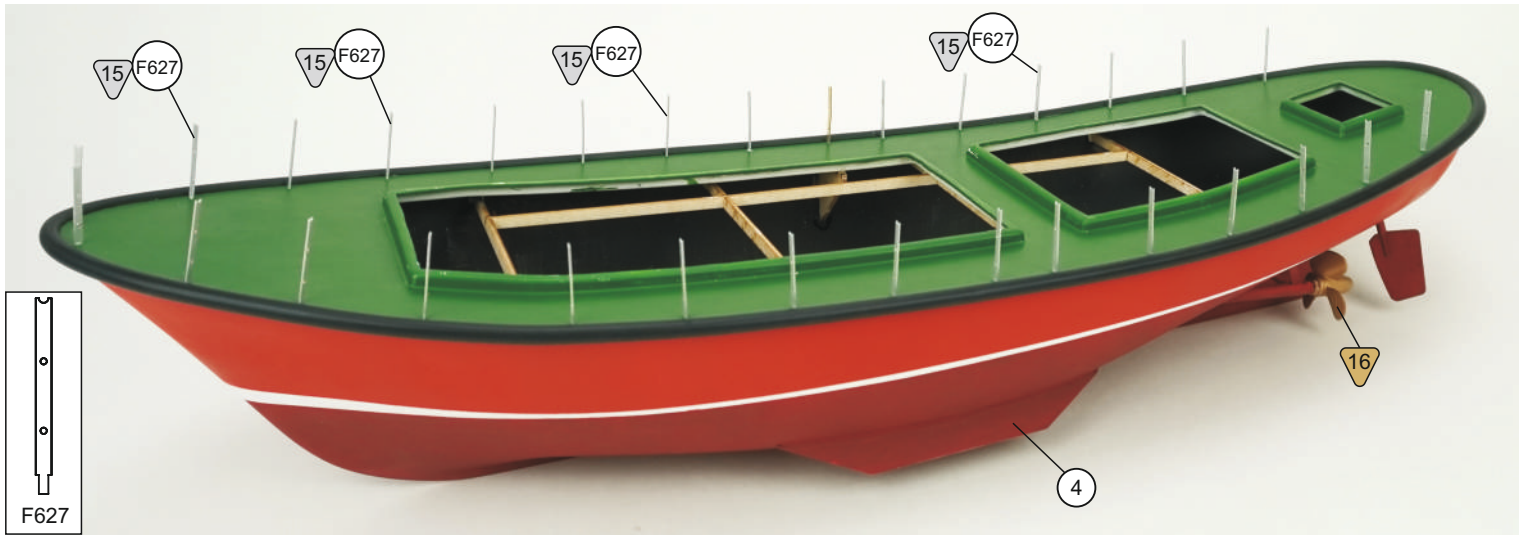

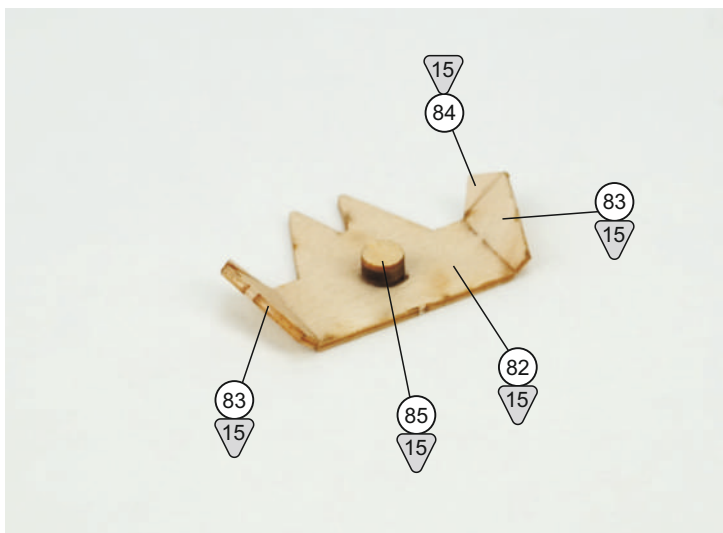
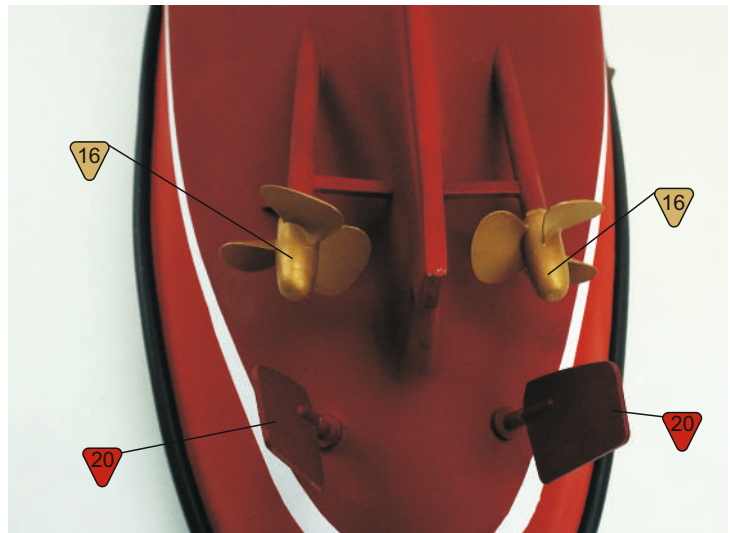
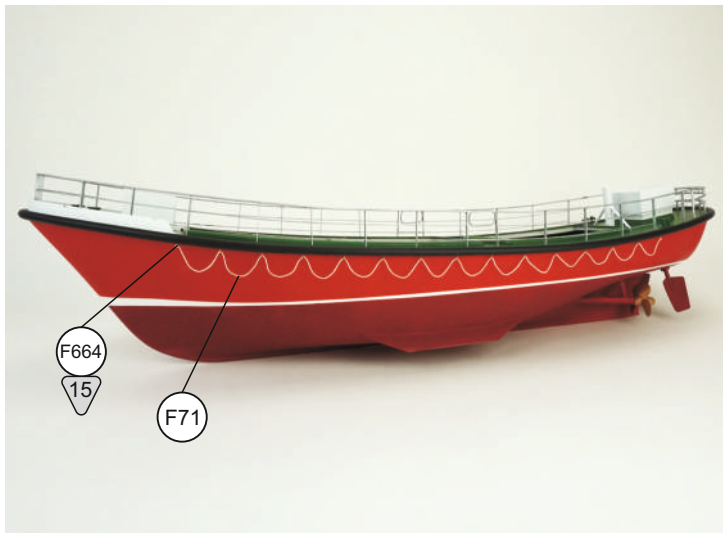

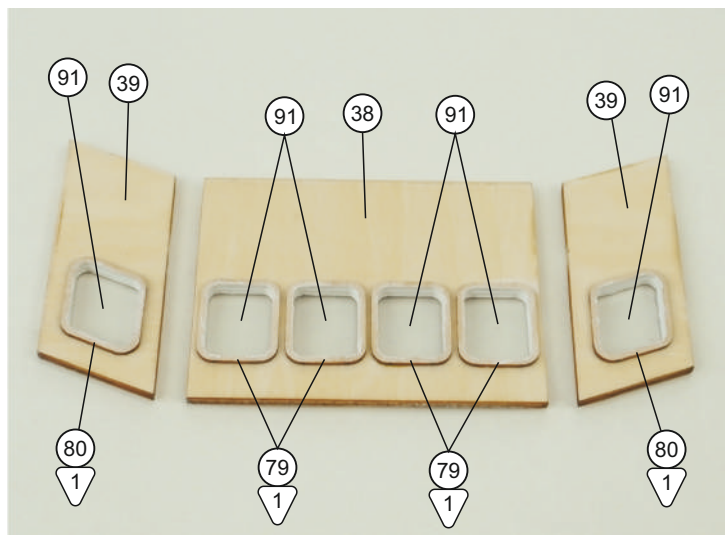
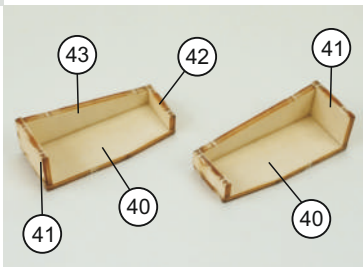
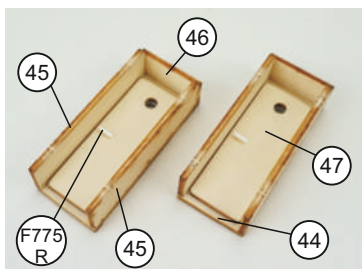
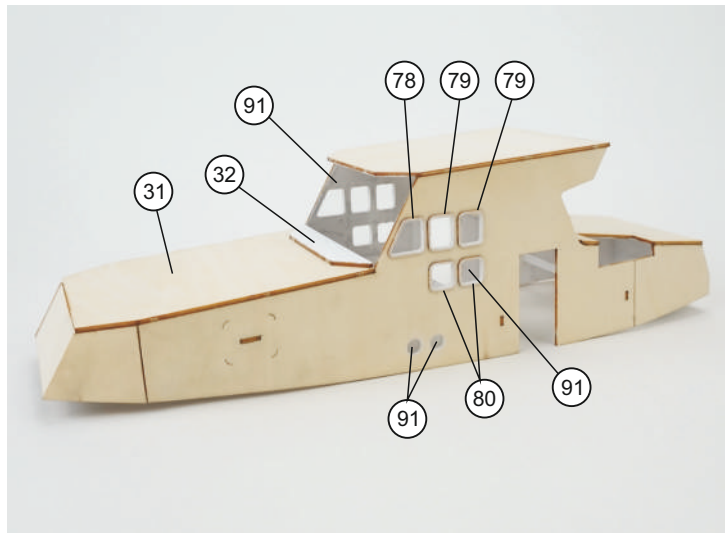
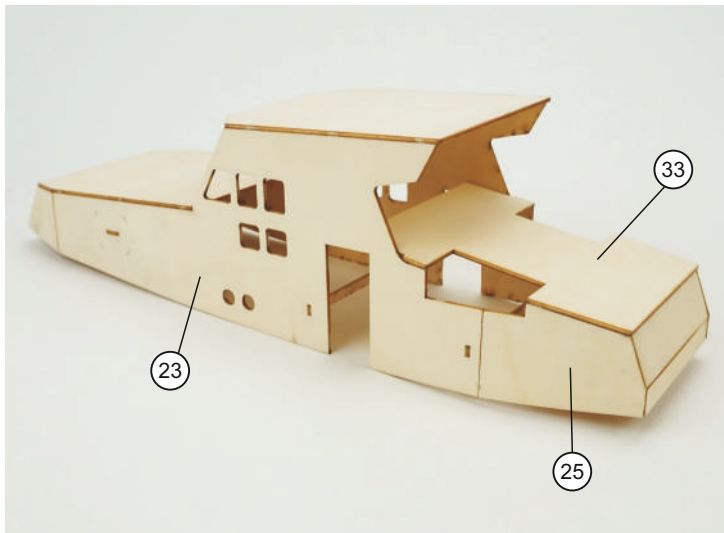
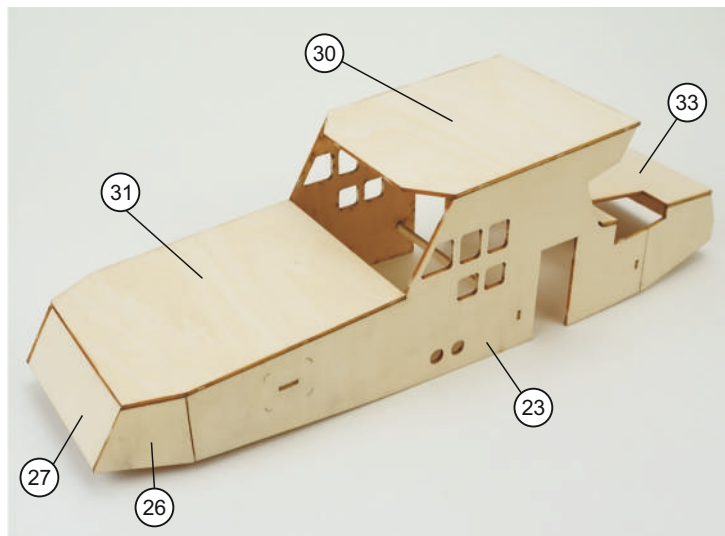
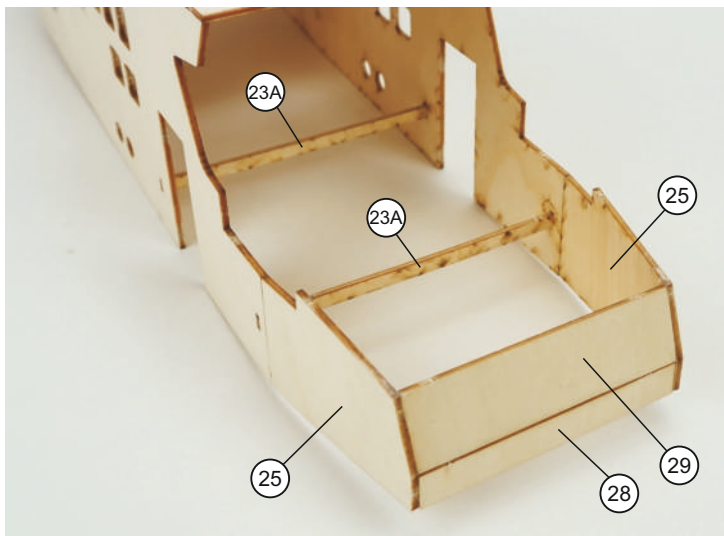
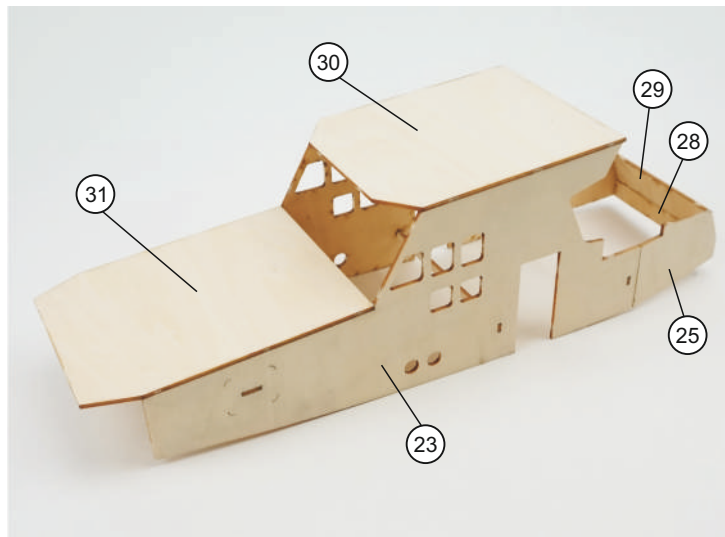
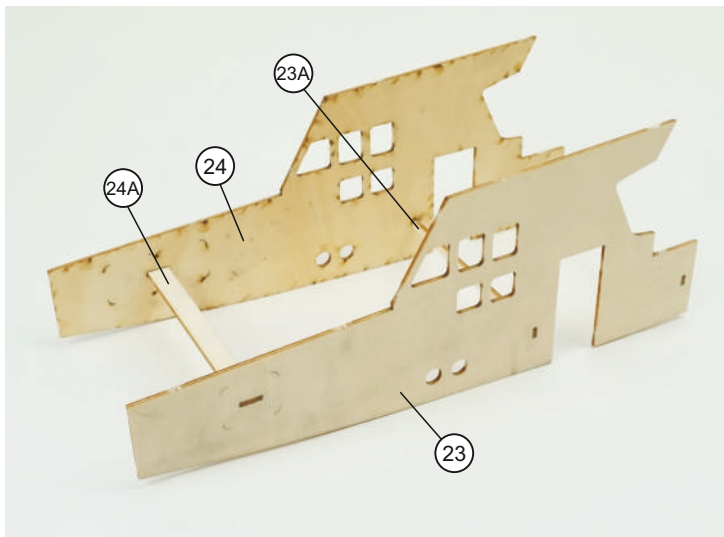

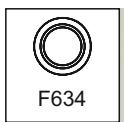
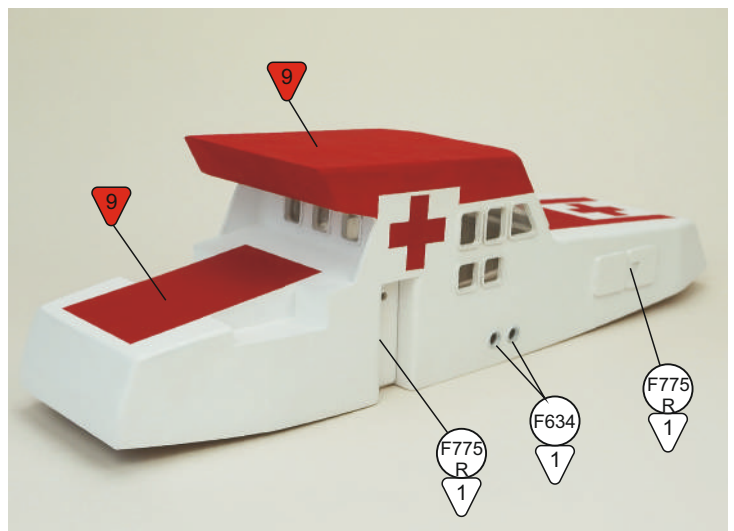
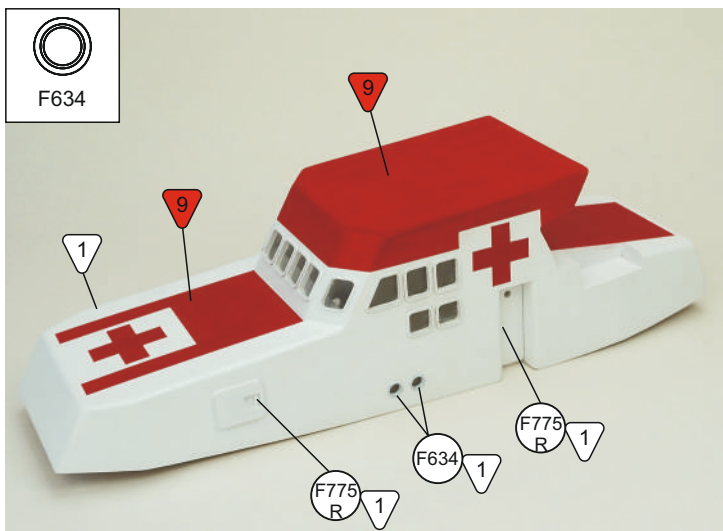
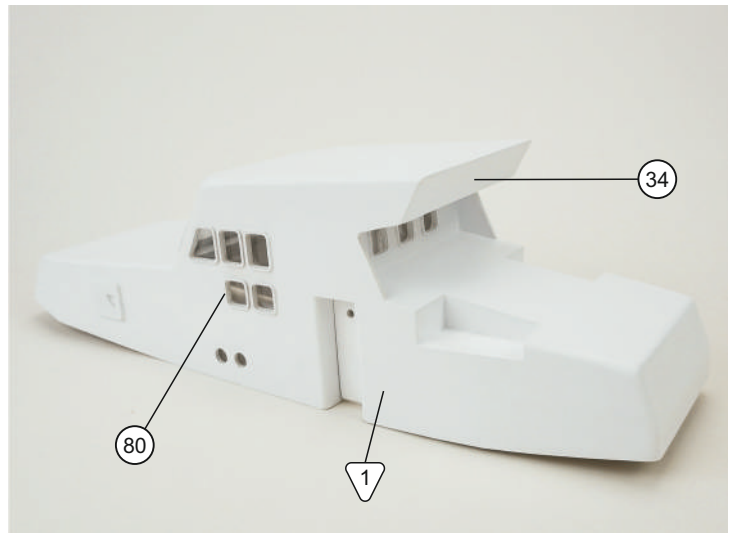
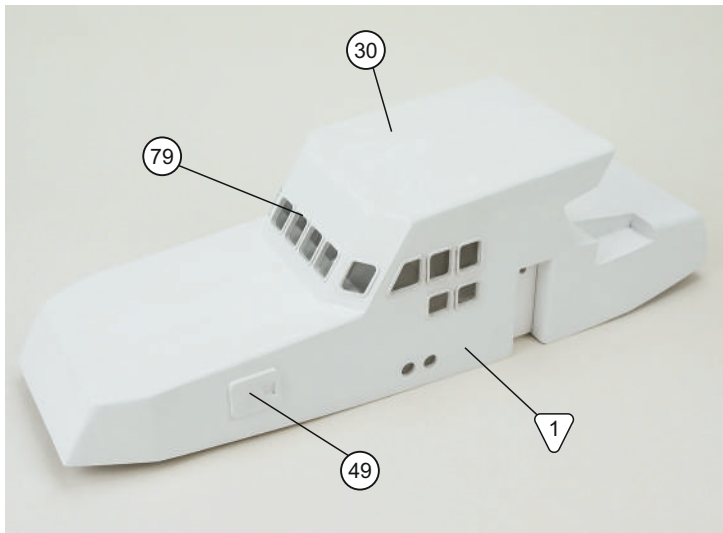
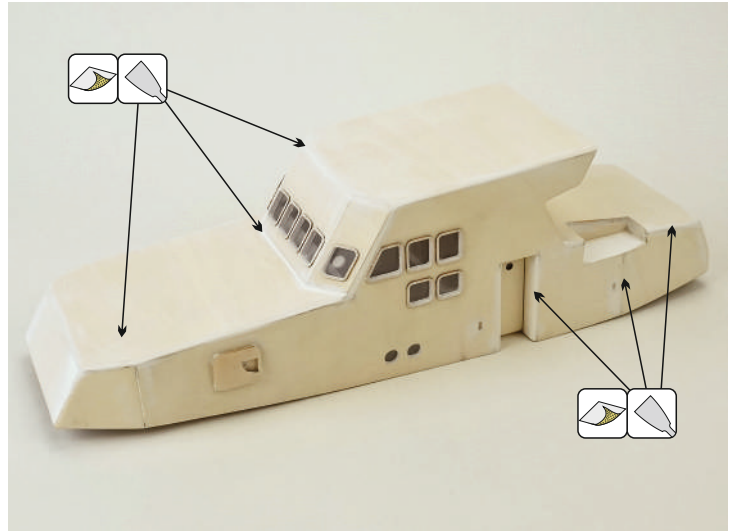
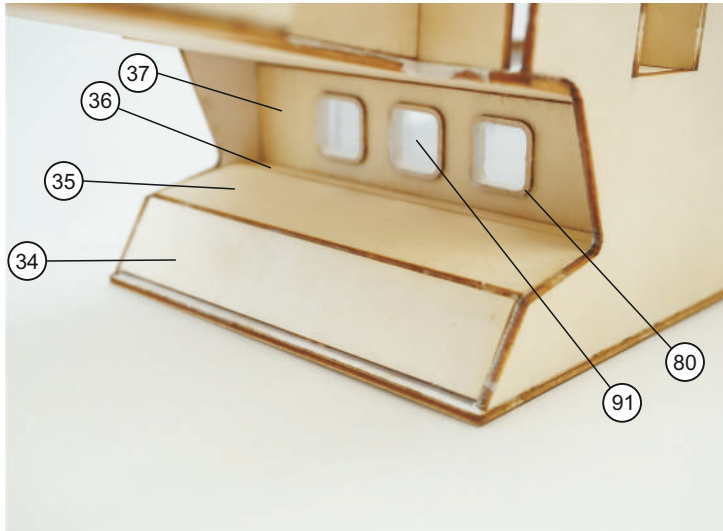
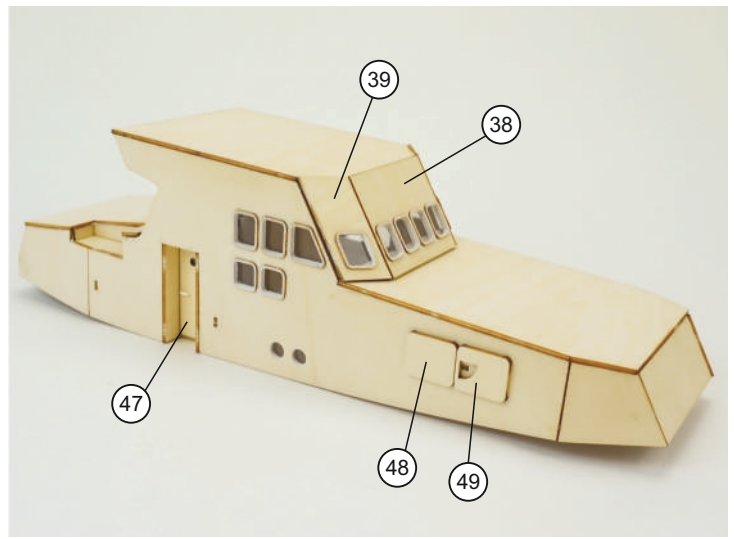
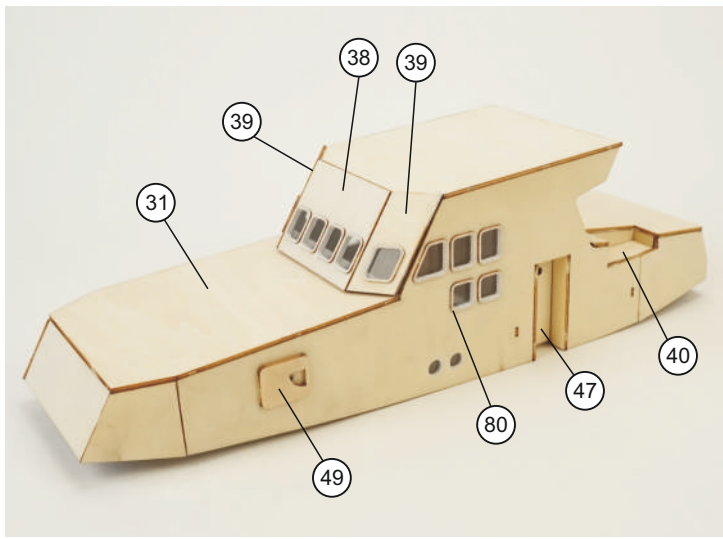



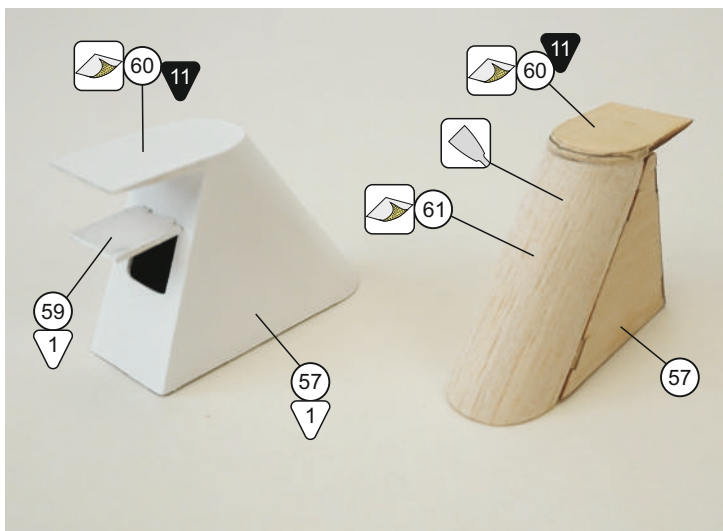
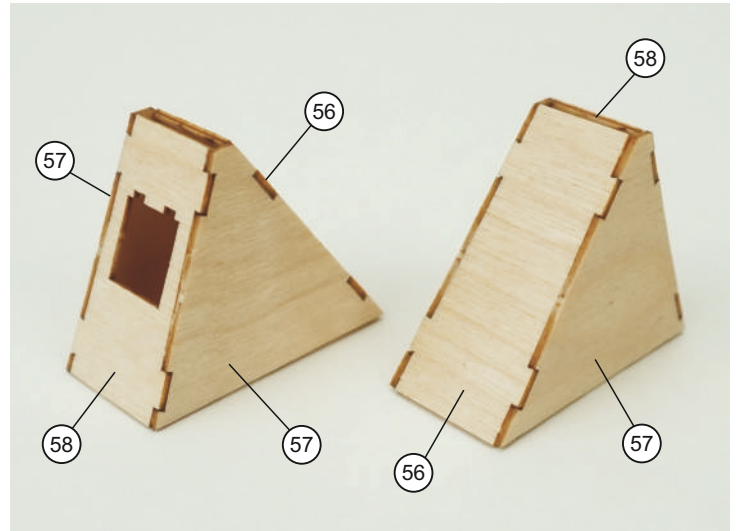
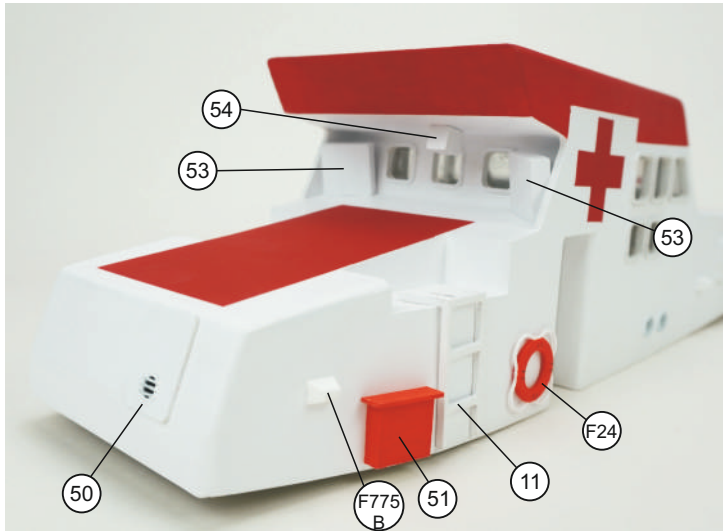
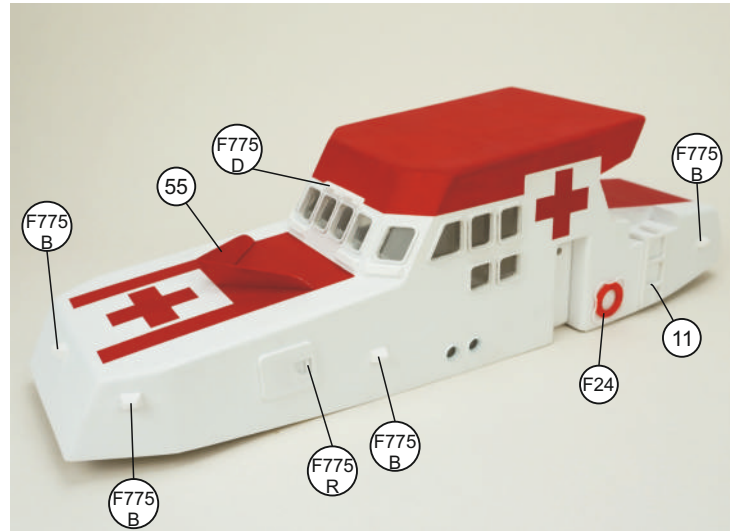
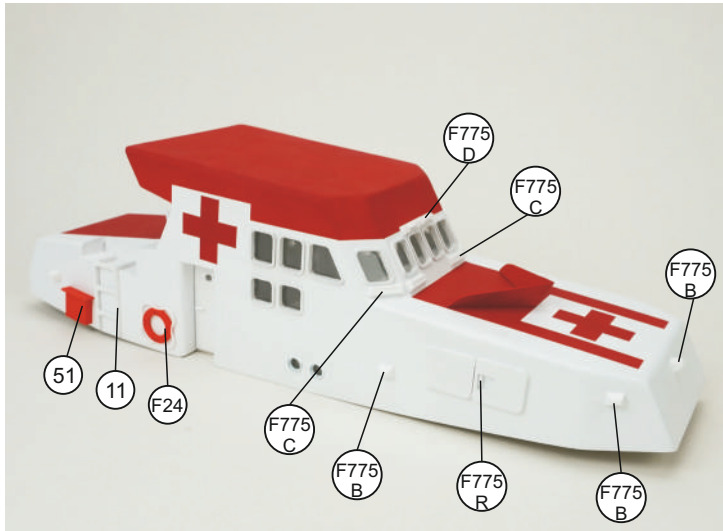
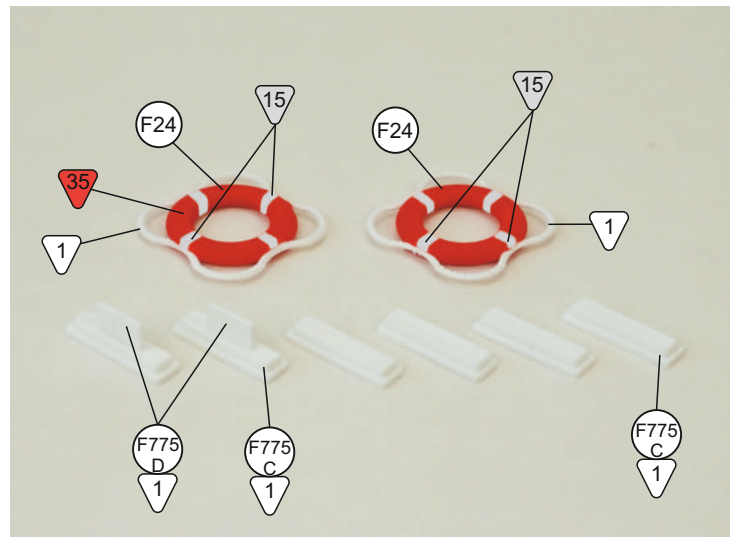
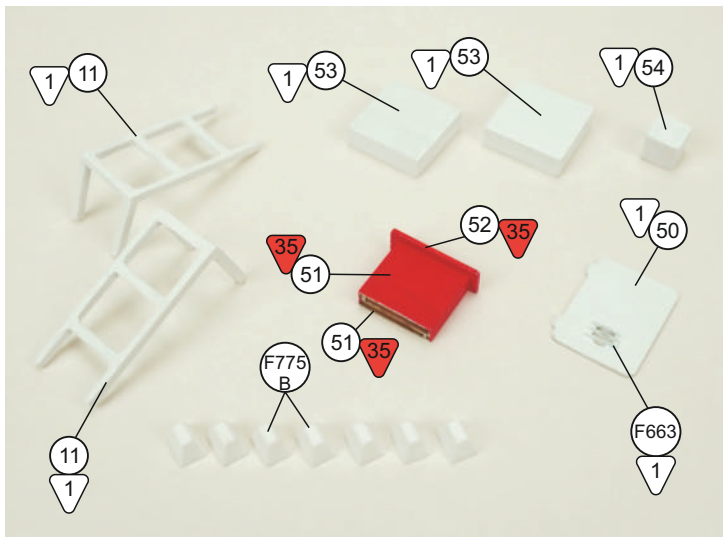

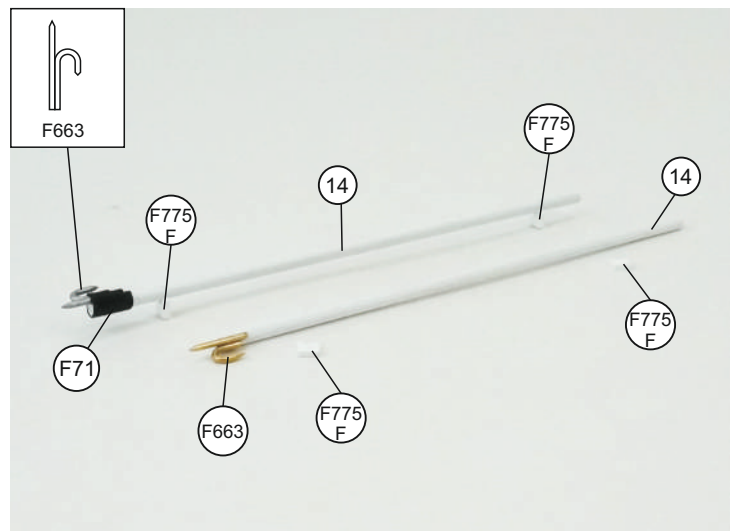
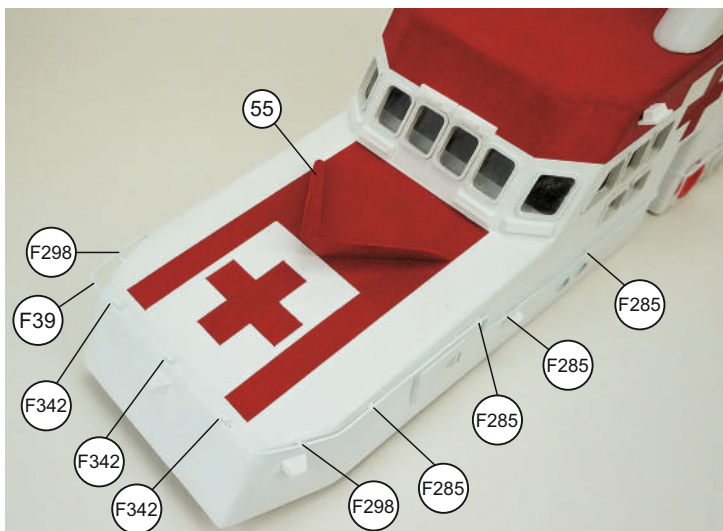
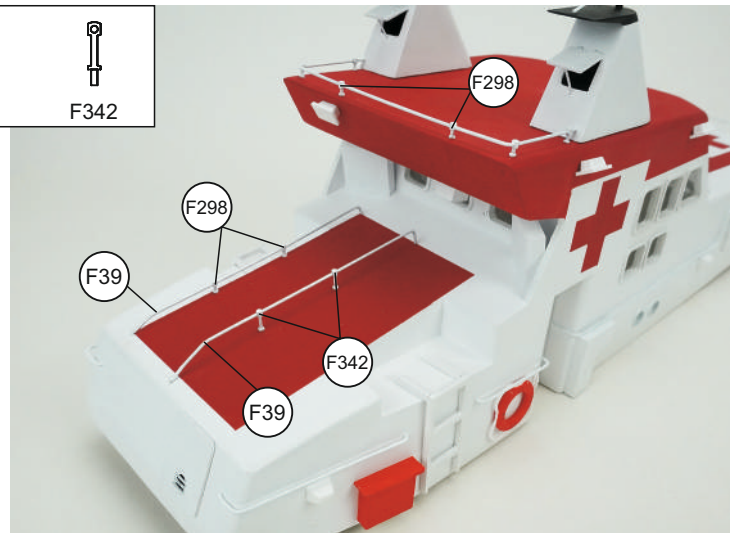
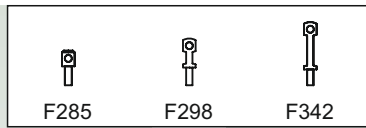
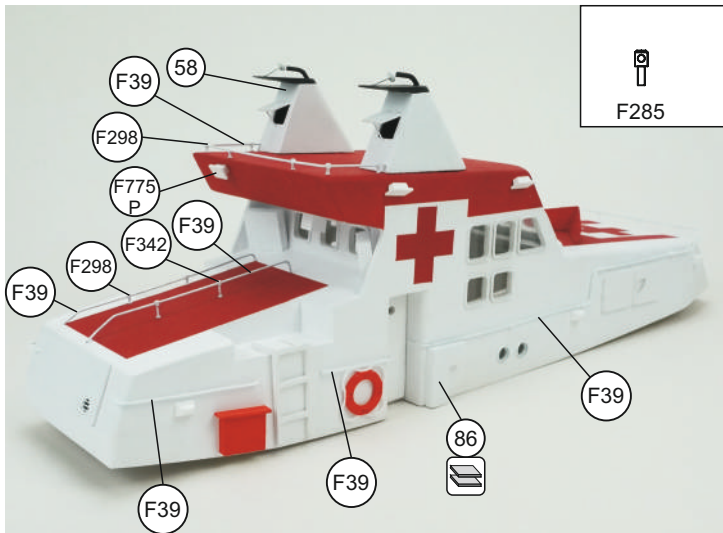
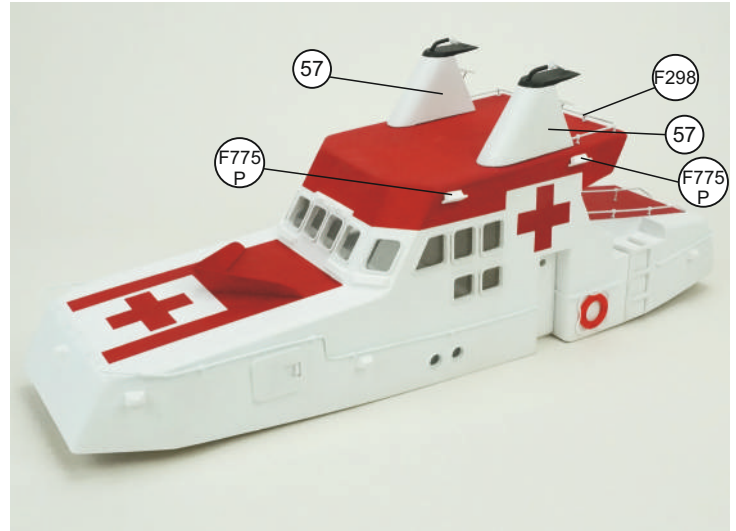
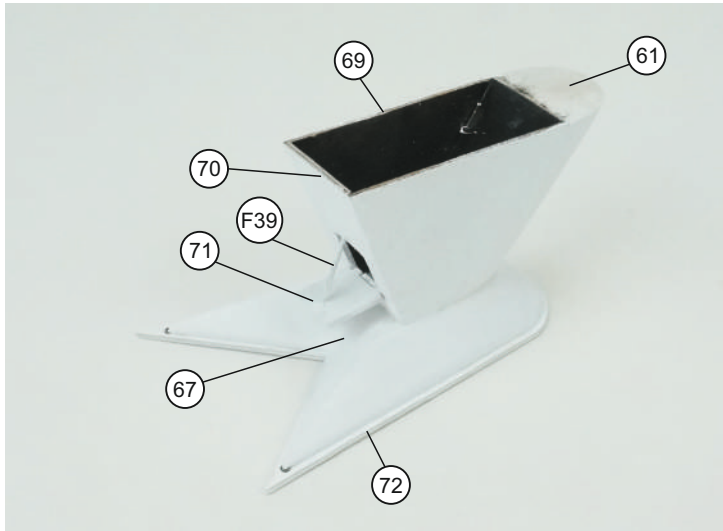
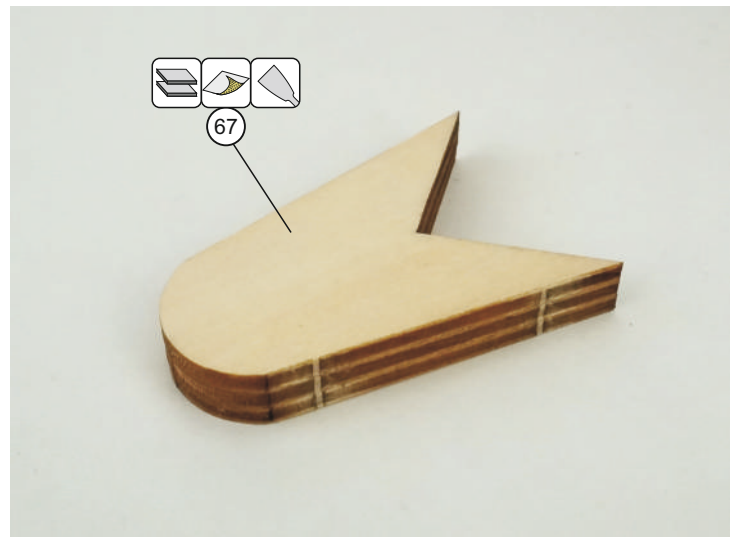
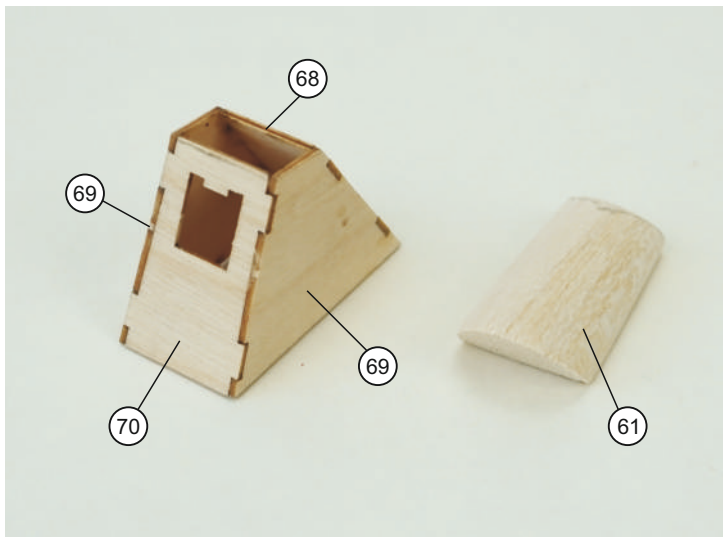

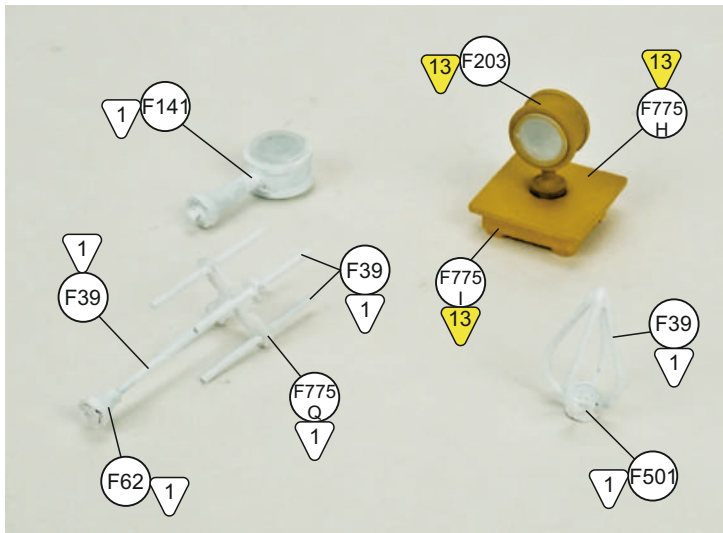
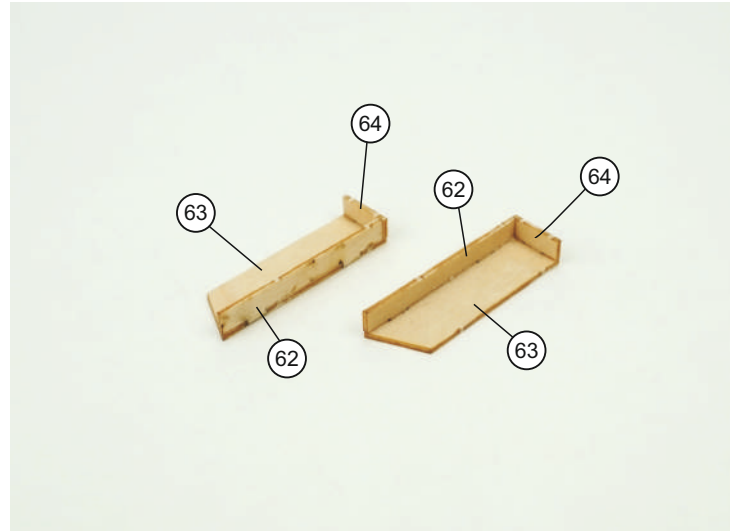
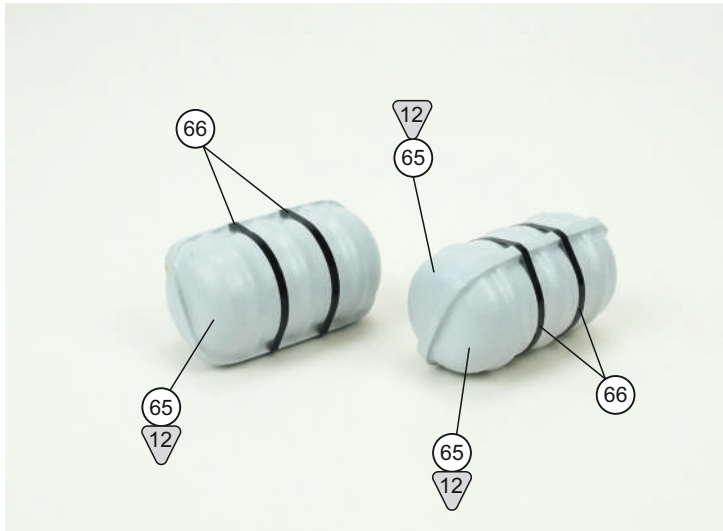
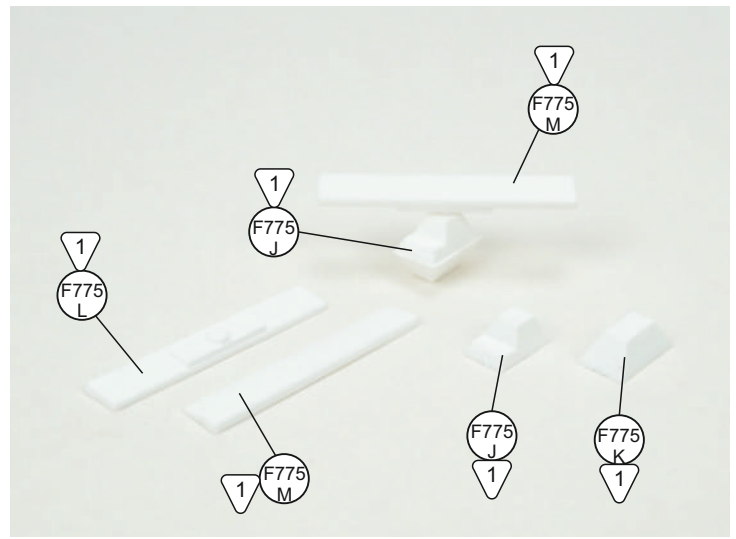
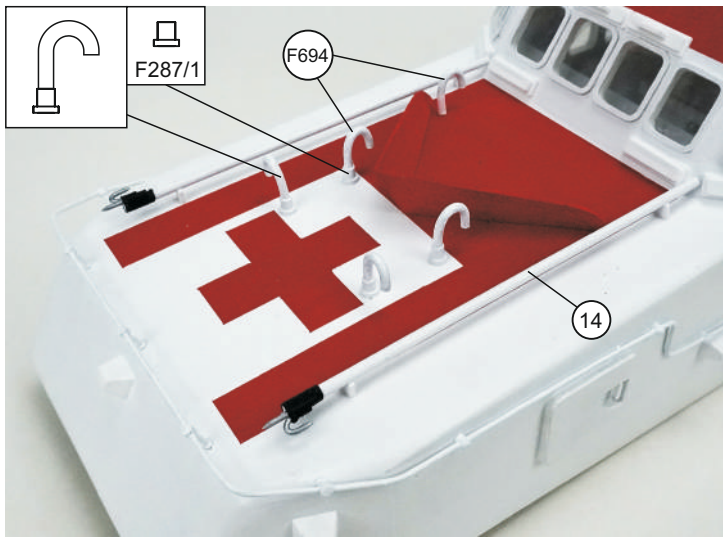

F141



F203



F777



F501



F62



F287/1

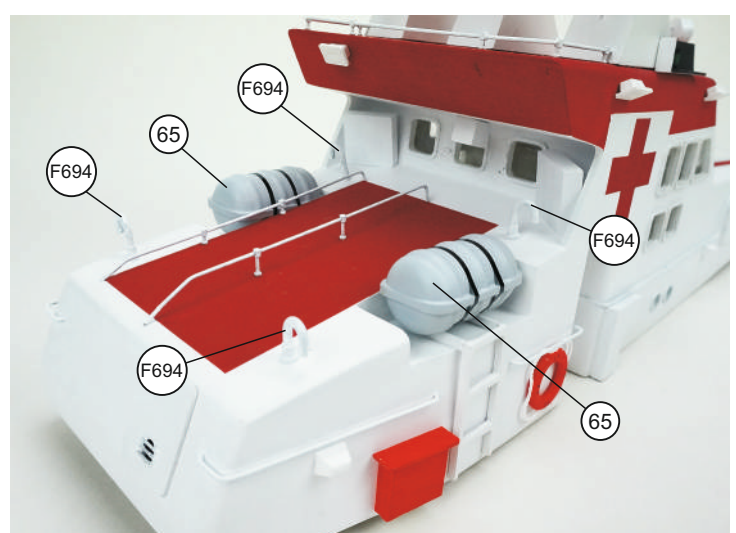
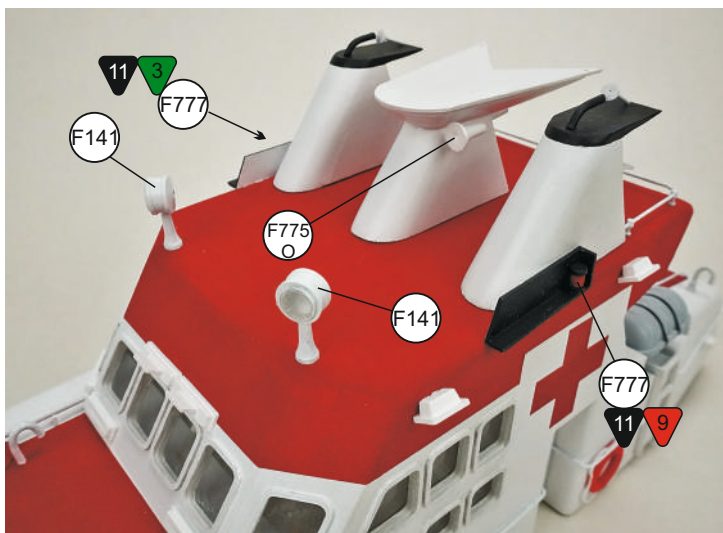

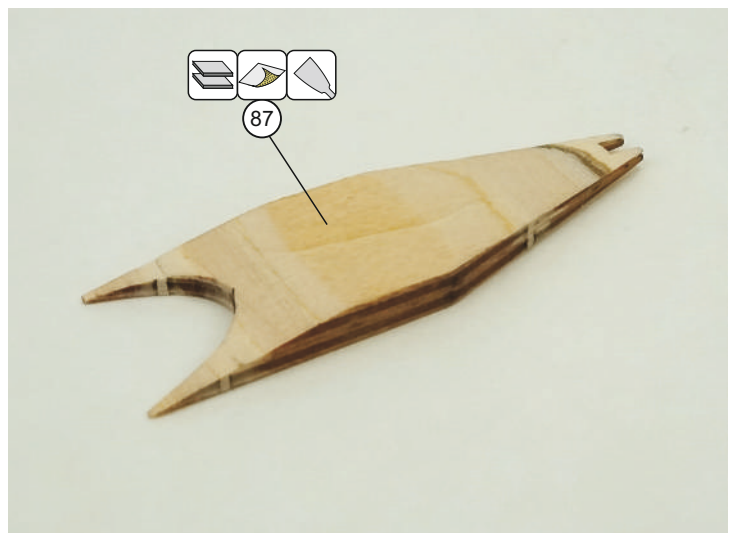
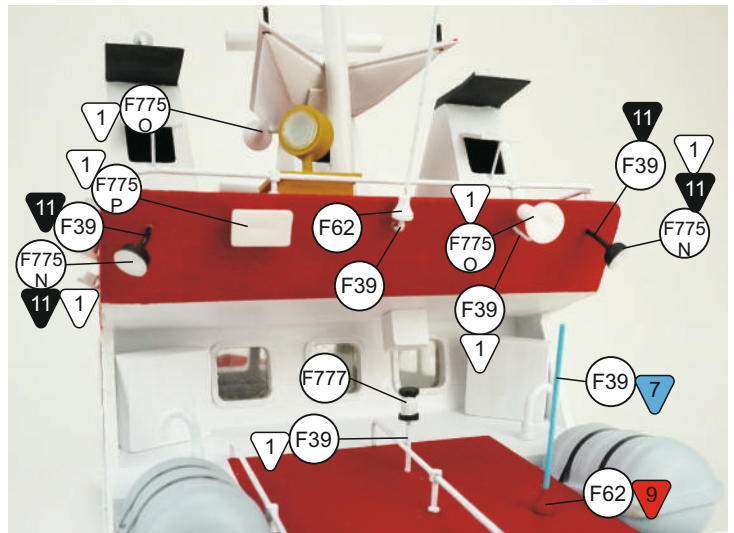
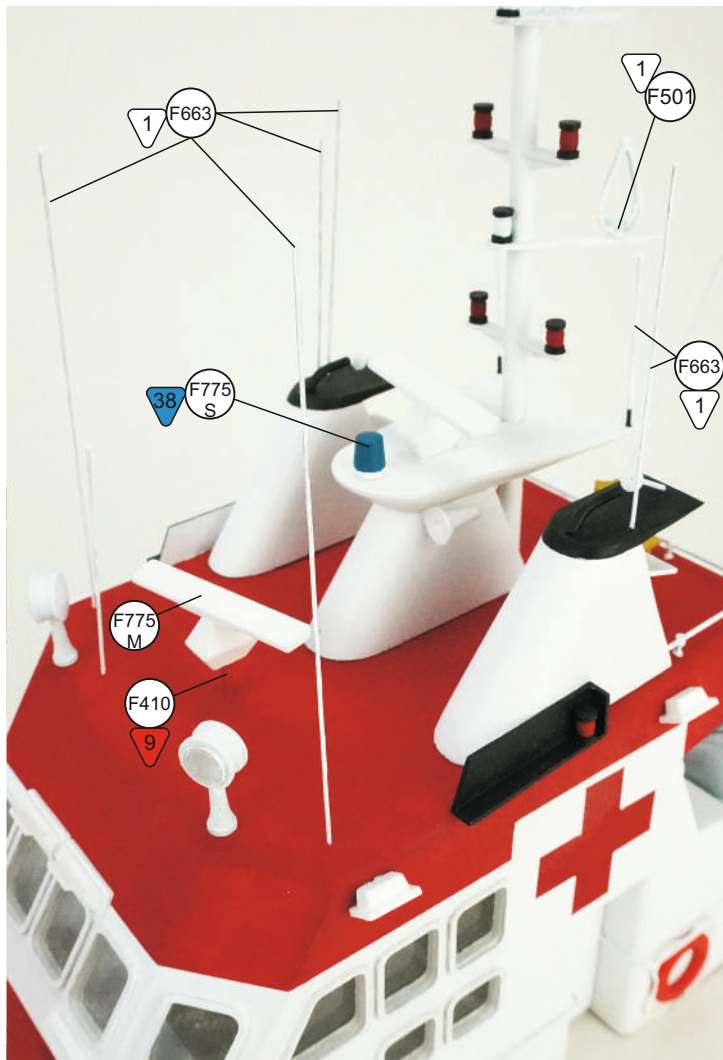
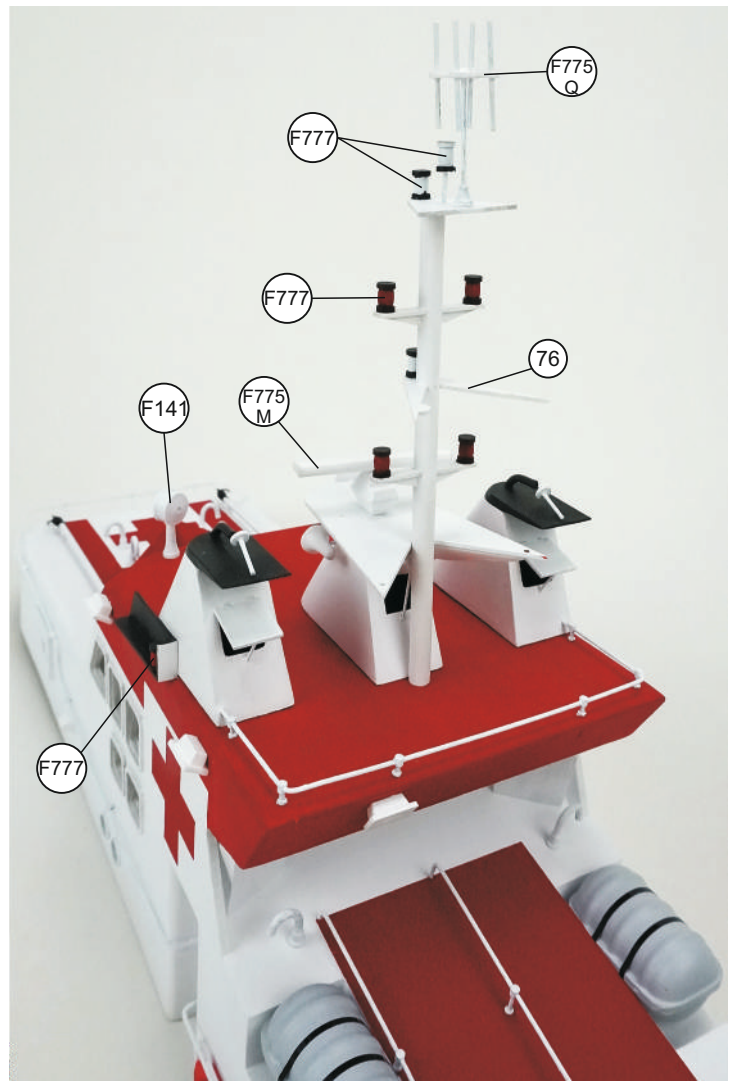
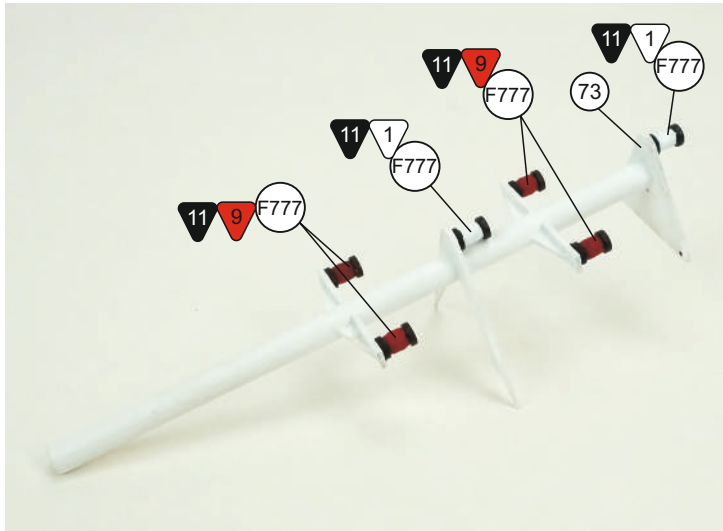
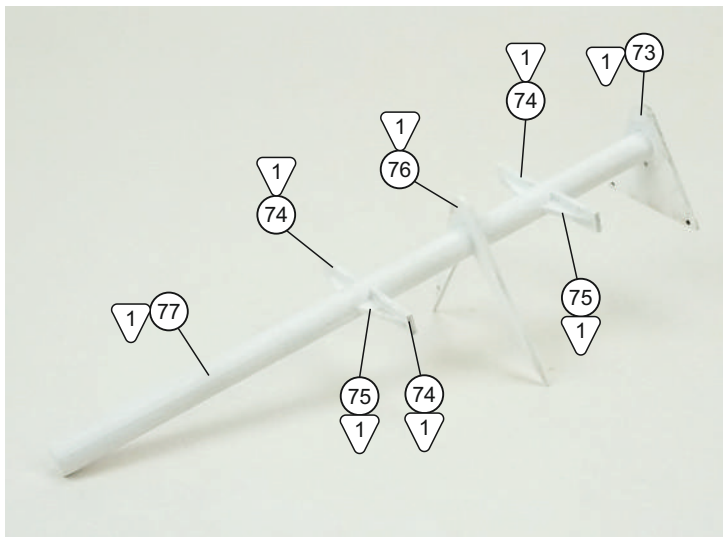

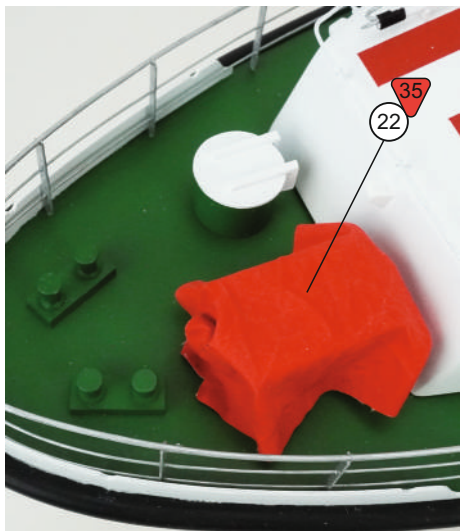
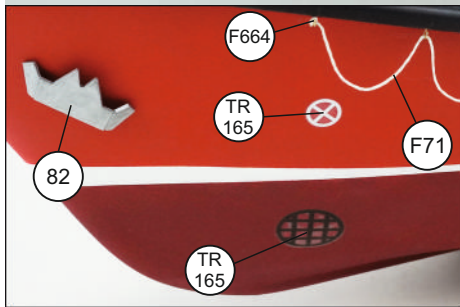
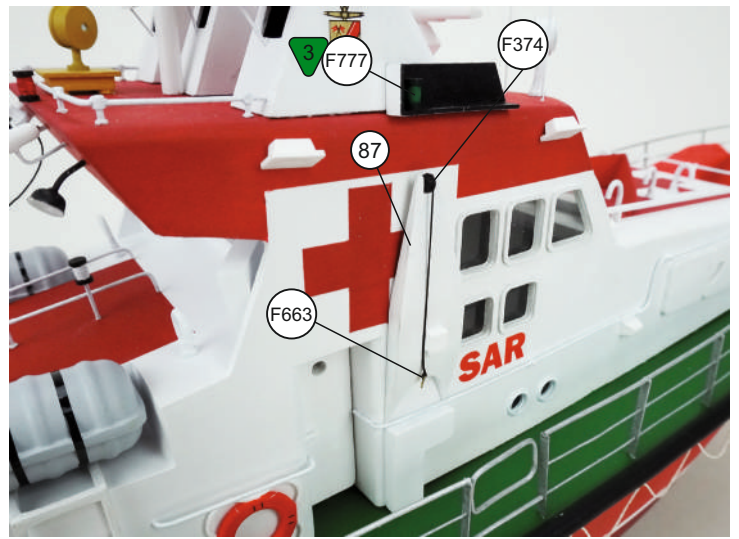
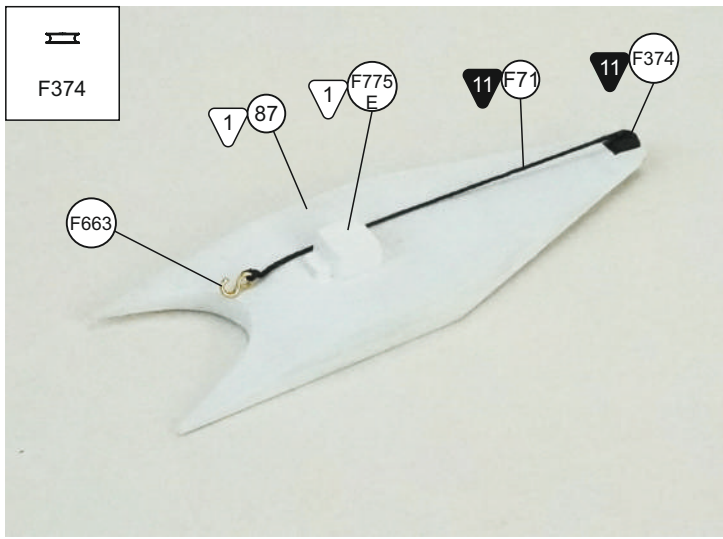







## **Billing Boats**

[www.billingboats.com](http://www.billingboats.com)  
[service@billingboats.dk](mailto:service@billingboats.dk)